



Fully Recessed Cooler

With Cup Dispenser



Standard finish is Stainless Steel

Optional Accessories (extra cost)

- Vandal-Resistant Kit
- Water Filter
- Easy-Flex™ Bubbler

Trap and service stop not included.

JOB NAME: _____

ENGINEER/CONTRACTOR NAME: _____

APPROVAL: _____

DATE: _____

MODEL RC8A-Q with 14762 (Cup Dispenser)



This water cooler is certified to NSF/ANSI 61.

GENERAL

Modular, electric refrigerated, fully-recessed wall-mounted water cooler designed to be easily accessible to physically challenged individuals. When properly installed, unit meets state and federal requirements as defined by the Americans with Disabilities Act for side approach. Unit is certified to NSF/ANSI 61 and meets requirements of the Safe Drinking Water Act. Unit provides 50° F water at 80° F inlet water and 90° F ambient.

CUP DISPENSER

Stainless steel with satin finish, fully recessed, single door with two locks, dual cup canister (one reserve). Removable waste bin. Accepts standard 2 3/4" rim dia. cone or paper cups.

FOUNTAIN

One-piece, non-corrosive stainless steel cooler top, number 300 series with satin finish and contour-formed basin.

AUTOMATIC STREAM HEIGHT REGULATOR

Self-closing assembly is located inside unit to prevent tampering. Unit resists corrosion and lining. A constant stream height is automatically maintained under line pressures that vary from 20 to 105 psi.

BUBBLER

Exclusive one-piece, chrome-plated two-stream mound-building bubbler with non-removable anti-squirt feature and integral hood insures a satisfying drink of water.

PUSHBUTTON ACTUATION MECHANISM

Self closing, vandal-resistant pushbutton does not require grasping or twisting.

INLET STRAINER

Easily cleaned in-line strainer screen traps particles of 140 microns or larger before they enter the waterway.

REFRIGERATION SYSTEM

Hermetically sealed, positive start compressor with lifetime lubrication and built-in overload protection, efficient capillary sizing, large capacity dryer-strainer, and self-lubricated fan cools copper/aluminum condenser. System uses R134A refrigerant. Protected by Halsey Taylor's Limited 5 Year Warranty.

MOUNTING FRAME

Mounting frame is manufactured of corrosion resistant, galvanized steel. Open construction designed for ease of installation. Mounting frame can be shipped in advance for rough-in installation.

CABINET AND ACCESS PANEL

Cooling unit contained in a heavy gauge galvanized steel cabinet with front and rear panels removable for service. The upper louvered panel is easily removable for access to the chiller unit system.

SUGGESTED SPECIFICATIONS

Shall deliver 7.5 GPH of 50° F water at 90° F ambient and 80° F inlet water. Fountain shall include pushbutton valve on front and contour-formed basin to eliminate splashing and standing water. Bubbler shall be chrome plated, two-stream, mound-building type. Cooling unit shall have a high efficiency positive start compressor using R134A with pressurized counterflow cooling evaporator/chiller. Cooler shall comply with ANSI 117:1 and **ADA for side approach only**. The manufacturer shall certify the unit to meet the requirements of NSF/ANSI 61, and the Safe Drinking Water Act. Unit complies with ARI Standard 1010.

NOTE: Continued product improvement makes specifications subject to change without notice. See Halsey Taylor website for most current spec sheet.

RC FULLY RECESSED SERIES

Model No.	GPH Capacity Cooled to 50° F*				Base Rate Cap.	F.L. Amps	Shipping Weight lb.	Rated Watt Usage
	Ambient Air Temp							
	70°F	80°F	90°F†	100°F				
RC8A-Q w/14762	9.1	8.3	7.5	6.5	7.5	4.0	121	370

* With projector service and tap water at 80° F

† UL listed and complies with ARI Standard 1010



* For parallel approach only

RC8A-Q with 14762

Cup Dispenser for Fully Recessed Cooler

(CONTINUED)

MOUNTING HEIGHT

Adult mounting height recommended 40" from basin to floor. May be mounted at any desired height.

WALL OPENING

Cut a wall opening 24 7/8" W x 48 1/2" H, 16 1/8" above the floor line. Inside of this opening add (1) 1 1/2" stud to make two openings: (1) 17 1/8" x 48 1/2" H on left hand side and (1) 6 1/4" W x 48 1/2" H on right hand side.

PLUMBING SUPPLY CONNECTIONS

3/8" copper tubing to wall box. Connection to the cooling unit requires 3/8" tubing connection.

ELECTRICAL SUPPLY CONNECTION

3/8" or 1/2" (7/8" actual) conduit connection to the remote chiller.

MOUNTING INSTRUCTIONS

Refer to rough-in for location of plumbing and electrical sources. The support frame is to be installed first. The shelf for the water chiller should be assembled to the wall frame, and then place chiller into position. Hang basin to hanger on frame and attach basin bottom to wall frame. Water service line, waste line and electrical is assembled as required. The bottom panel is attached last, after a final check for leaks and correct functions of fountain and chiller. (For details see the installation instructions.)

Installation requires trap to be installed in wall. Trap and service stop not included.

OPERATING PRESSURES

Supply water-105 psi maximum

ELECTRICAL DATA

Junction box for a (3) wire 10 AMP branch circuit. Standard 120 volt, 60 Hz, single phase.

MOUNTING INSTRUCTIONS FOR CUP DISPENSER

Open door of cup dispenser and remove waste bin. Use a straight edge to align top and bottom surface of cup dispenser with unit previously installed on the left hand side.

Check vertical gap between door and cooler unit, allow 1/8" gap (shim to suit). Open door of cup dispenser and fasten box with screws or bolts (as required by wall construction) through slots provided.

TOP VIEW

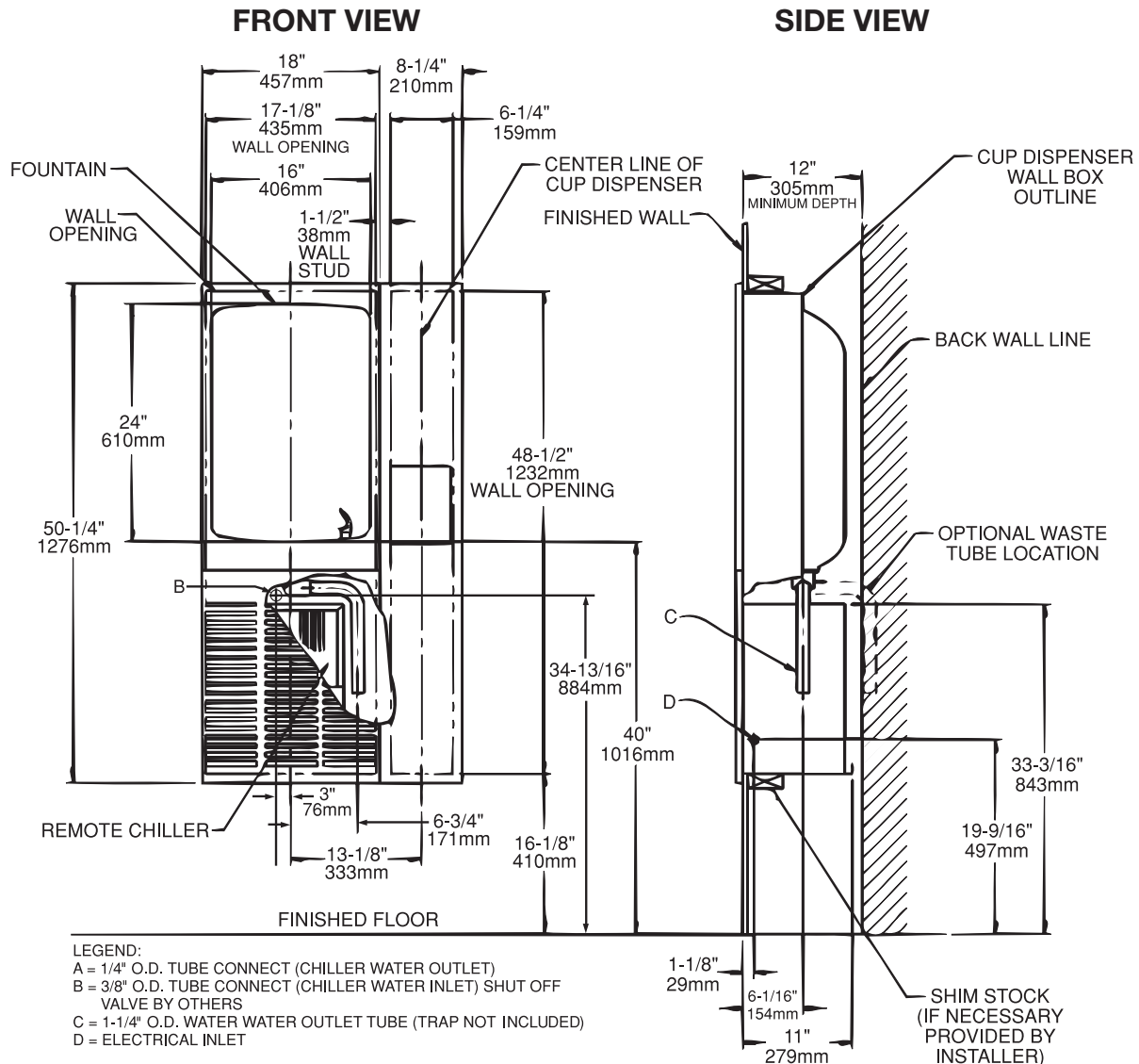
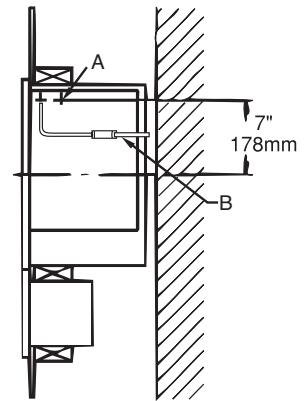

Halsey Taylor®